

Please read this Manual carefully before installing and using the product.

# AW-D306H Addressable Sounder Beacon

## 1 Product overview

- (1) AW-D306H Addressable Sounder Beacon can give audible and visual alarms after being connected to a bus loop. It can be used with a bus-type fire alarm control panel. The acousto-optic alarm is controlled by microprocessor, with 7 tones to choose from, and can communicate with the Control Panel in real time to receive control commands from the Control Panel. When an accident occurs, the Sounder Beacon receives the start command from the Control Panel and then acts to send out dazzling flash signals and ear-splitting acoustic alarm signals to remind the personnel on the spot to quickly understand that a fire has occurred on the spot and take measures to evacuate as soon as possible to avoid major accidents. Pressing the 'reset' button on the Control Panel, the audible and visual alarm can be restored to the monitoring state.



The Sounder Beacon may be used to give audible alarms at the scenes of accidents. It is applicable to places like high-rise residential buildings, public places, hotels, amusement buildings, factories, shopping centers, hospitals, schools, office buildings and stock exchanges, and particularly to the places with a low visibility or the possibility of generation of smoke.

## 2 Product features

- (1) Choice of up to 7 tone modes.
- (2) Adopting independent base, it is simple and convenient for installation, commissioning and maintenance.
- (3) Full electronic coding, address numbers and operating modes can be rewritten on-site through the encoder, through the encoder can be set up as a normal type of audible and visual alarm.
- (4) Sounder Beacon working mode can be set freely, sound and light alarm at the same time, or sound or light independent alarm, adapted to different working environments.
- (5) The light display adopts multiple ultra-high brightness light-emitting diodes as the light source, with eye-catching display, long life and low power consumption.
- (6) Tamper-evident function is possible.
- (7) Available in red and white colour options.

## 3 Technical parameters

Item	Parameters
Executive standard:	EN 54-3 (Type A)
Working voltage:	DC24V (allowance: DC22V ~ 28V)
Power consumption	≤0.29W@DC24V
Working current:	Standby current:<0.8mA,Alarm current: 1mA~12mA
Wiring method:	non-polarity, two cables

Operating environment:	Indoor, temperature: $-10^{\circ}\text{C}\sim+55^{\circ}\text{C}$ ; Relative humidity: $\leq 95\%$ ( $40^{\circ}\text{C}\pm 2^{\circ}\text{C}$ , without condensation)
Flash Rate	1~1.5Hz
Maximum sound output:	$\geq 104\text{dB(A)}@1\text{m(Tone2@90}^{\circ})$
Tone type	7 User-Selectable Tones (EN54-3 approved for tone2 Only)
Material Lens/Body	Flame retardant PC/ABS
Weight:	about 202g(with base)
IP Rating:	IP21C
Overall dimensions:	$\phi 112 \times 100(\text{mm})(\text{With Base})$

**4 Appearance and dimensions**

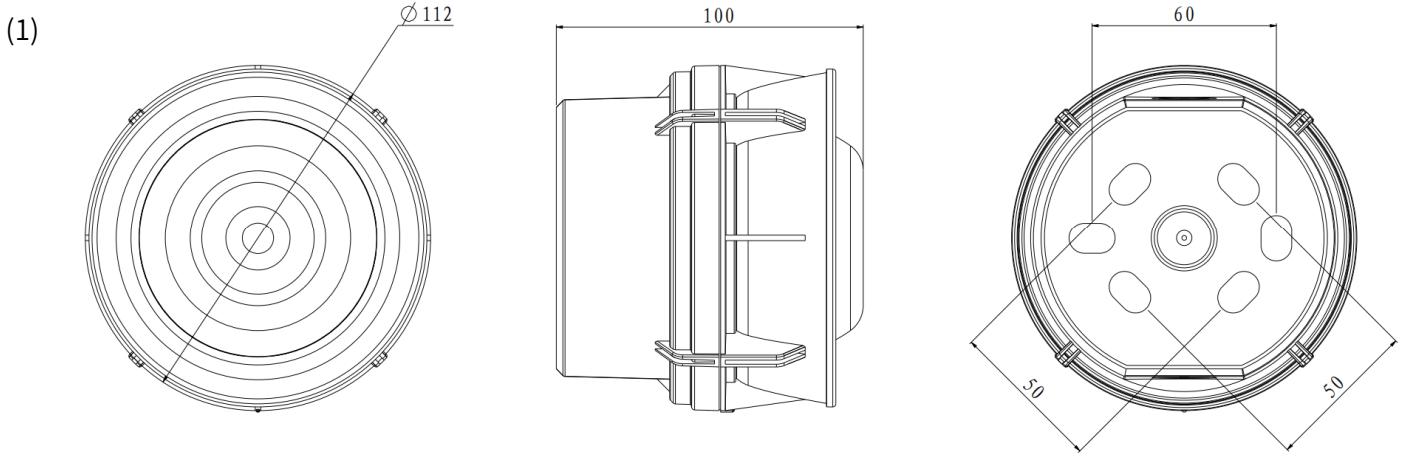

Fig.1 AW-D306H (Unit: mm)

**5 Use and engineering application**

(1) Wiring Terminal Diagram

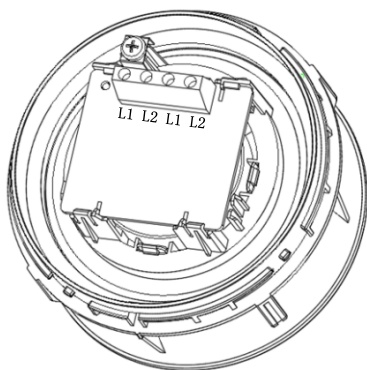

Fig.2

Definitions of terminals (non-polarity two-cables system):

- L1 – Signal terminal
- L2 – Signal terminal

(2) Wiring mode 1: the Sounder Beacon is connected to the fire alarm Control Panel circuit wiring diagram:

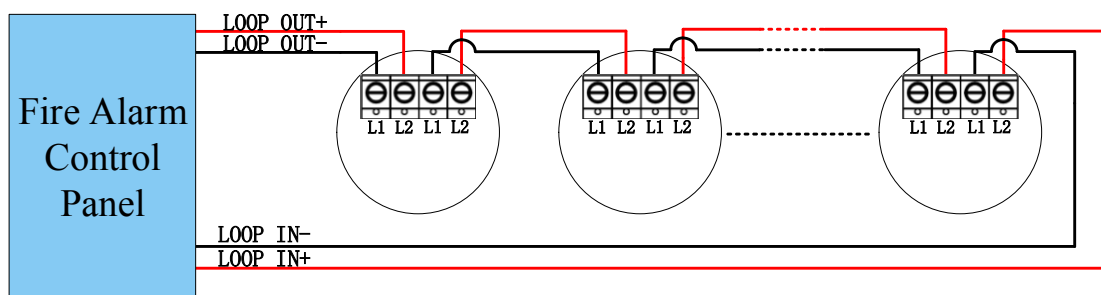

Fig.3

- (3) Address coding mode: Please connect the coder and Sounder Beacon correctly according to the wiring in Fig. 3, L1L2 is non-polarity connection, set the coder to coding function, compile the correct address code, press the ‘OK’ key to complete the address coding setting. (Note: For detailed operation, please refer to the encoder manual)

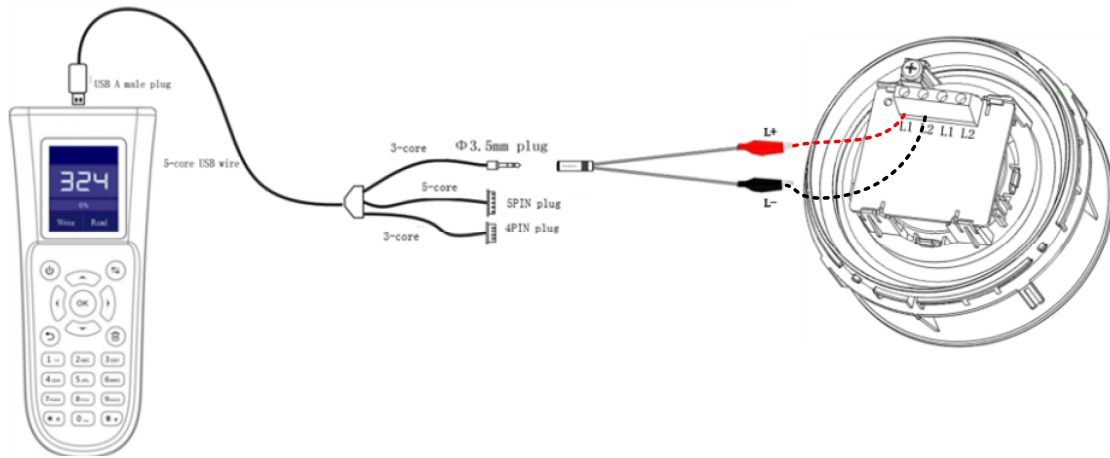

Fig.4

- (4) Mode code: The modes of the Sounder Beacon are all set by the coder, and there are four different modes in total, which are divided into Sounder Beacon/Sounder/Beacon mode, Intelligent/Conventional mode, Tone mode, and mute non-stop beacon mode. The wiring method is shown in Fig. 4, the interface is shown in Fig. 5.

Press the following steps to operate:

- A. In the main interface, Selected ‘Coder’ → ‘ModeSetting’ ;
- B. When the cursor stays in ‘ModeSetting’ , it can be changed to ‘Sounderset’ by ‘↓’ key;
- C. Press ‘TAB’ key, the cursor will be Stay in ‘FunctionSelection’ , press the ‘OK’ key, you can select the required mode setting through the ‘↑’ key or ‘↓’ key;
- D. After selecting the required Function, press the ‘TAB’ key, the cursor stays in ‘Mode’ , press the ‘OK’ key, you can select the required mode value ‘↑’ key or ‘↓’ key as shown in Table 1~4;
- E. After selecting the corresponding mode code and mode value, press the ‘TAB’ key, put the cursor in ‘Write’ to write the currently set mode value, or put the cursor in ‘Read’ to read the mode value of the currently selected mode.

Note: the address must be coded correctly first, and then mode code; please refer to the encoder manual for detailed coding operation.

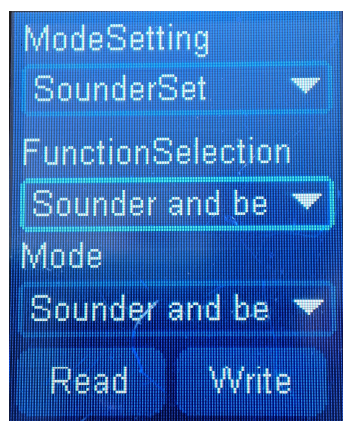

Fig.5

Function Selection	Mode	Default Mode
Sounder and beacon	Sounder and Beacon	√
	Only Sounder	
	Only Beacon	

Table 1 -- Description of sounder Beacon mode values

Function Selection	Mode	Default Mode
Addr/Conv Mode	Addressable	√
	Conventional	

Table 2 -- Description of Intelligent/Conventional mode values

Function Selection	Mode	Tone Description	Default Mode
Tone Mode	Tone1	Sweep 800Hz-2200Hz@0.3Hz	√
	Tone2	Sweep 1800Hz-3470Hz@0.42Hz	
	Tone3	Sweep 800Hz-970Hz@1Hz	
	Tone4	970Hz Continue	
	Tone5	(Swedish)660Hz 150ms on/ 150ms off	
	Tone6	(NZ)500Hz - 1200Hz,3.5s on /0.5s off	
	Tone7	Sweep 2400Hz-2850Hz@1Hz	

Table 3 -- Description of Tone mode values

Function Selection	Mode	Mode Description	Default Mode
StpNOClrLED Mode	Normal Mode	When Sounder Beacon is activated, the control panel presses silence key or issue a stop command, the Sounder Beacon will stop all alarm instructions back to normal.	√
	StpNOClrLED Mode	When Sounder Beacon is activated, the control panel presses silence key or issue a stop command, The Sounder Beacon will only stop the sound output, the beacon will run until reset.	

Table 4 -- Description of StpNOClrLED mode values

## 6 Installation and debugging

- (1) Base Installation Diagram(Note: the base is integrated with the body, the base is not available as a standalone product)

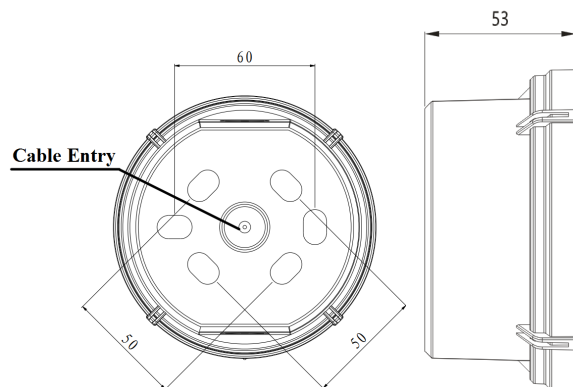

Fig.6 Base For AW-D306H

AW-D306H installation requires the use of supporting base, as shown in Figure 6. the diameter of the fixing hole  $\Phi 5\text{mm}$ , the fixing hole spacing for 50mm ~ 60mm. To install, you will need to tap down the cable entry holes in the base for wiring. Then use self-tapping screws to secure the base.

- (2) Wiring requirement: It is advisable to use RVS twisted pair with a cross-sectional area of  $\geq 1.0 \text{ mm}^2$ .
- (3) Tamper-proof function: If the Sounder Beacon siren needs to be tamper-proof, it needs to be secured in the tamper-proof holes on the base (see Fig. 7) using an ST2.9 x 6.5 screw.

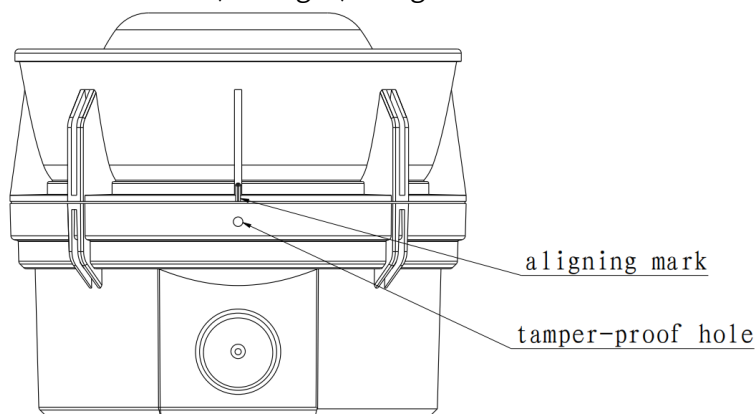

Fig.7

**(4) Installation and commissioning steps**

- Fix the matching base in the specified position according to the construction drawings using 2 x M4 screws through the mounting fixing holes shown in Figure 6 and should confirm that the base is securely fitted;
- Cut off the Control Panel working power, according to the construction drawings, firstly connect all the bases correctly in the way of figure 3;
- Confirm that the type of Sounder Beacon matches the type noted on the construction drawings; code the Sounder Beacon using the coder at the address number noted on the construction drawings;
- After all the Sounder Beacon have been installed and confirmed to be correct, switch on the power supply of the controller and carry out the automatic login operation;
- By pressing the Evacuate button on the control panel, all Sounder Beacon logged on the Loop will emit sound and light alarm signals. When the system is reset, the Sounder Beacon will stop outputting sound and light alarm signals.

**7 Caveat**

- (1) Please note the terminal markings when installing and wiring.

- (2) It is not permitted to have the same address between products in the same Loop, otherwise the system will not work properly.
- (3) When installing the Sounder Beacon, please note that there should be no objects in front of the siren that can block the flashing light or obstruct the sound.

**8 Maintenance**

- (1) Sounder Beacon are tested at least once a year.
- (2) Within the contractual warranty period, the company will be responsible for the free repair or replacement of the Sounder Beacon that have been used normally according to the specified requirements, if they fail due to defects in materials or manufacturing processes. If the sound and light alarm fails due to human damage, improper use or self-adjustment, alteration or disassembly, it is not covered by the warranty, and the Company will not be responsible for any adverse consequences caused as a result.
- (3) We may provide paid repair service for products with any faults beyond the guarantee range. If you have such products that need repair, please contact us. When sending such a product to us for repair, you are expected to provide some important information about the product, such as the phenomenon and possible cause of the product fault, so that we can find out the cause of the fault in the shortest time and so the information may be used as a reference in our future product development and improvement.

**9 Fault analysis and troubleshooting**

(1)

Failures	Causes	Methods	Remarks
No flash or Sound alarm signal	wiring error	Check for correct wiring	
	The C&E function is not turned on	Check that the control panel C&E settings are correct	
	Address code setting error	Check that the address code is correct	
	Mode code setting error	Check that the mode encoding is correct	
	Internal circuit is broken	Return to the manufacturer for repairs	

